

rimon **LNS**

CHATBOTS AND AI

New opportunities to serve
customers

Kordian Caplazi, Founder and CEO
Rimon Technologies GmbH
kordian@rimon-ar.ch

Philipp Saurer, Head of Digitalization and Group Marcom
LNS Management Sàrl
psaurer@lns-group.com



The global partner of choice automating manufacturing with innovative solutions.

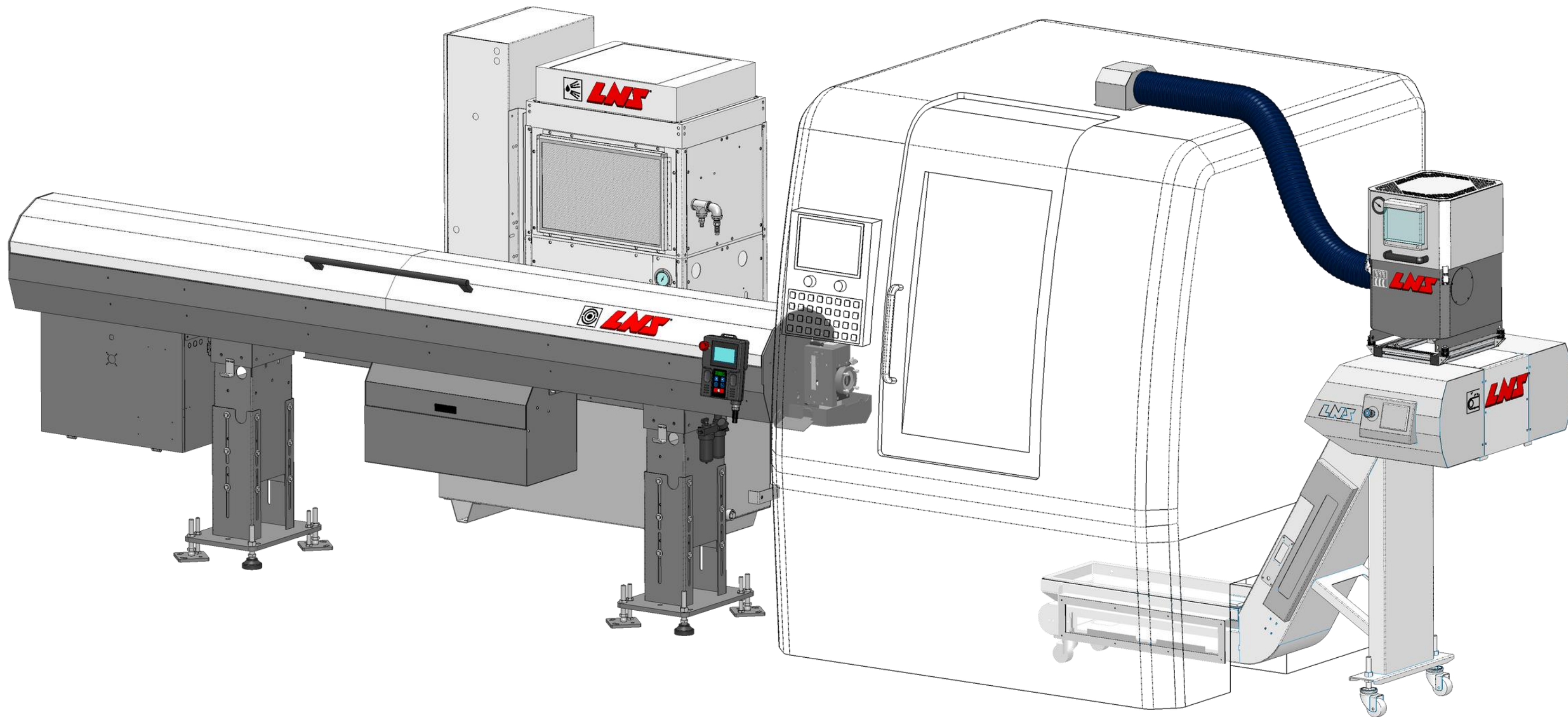



Swiss Leader in machine tool peripherals.



Operates globally, 9 production sites in Switzerland, Italy, UK, Taiwan, China, Japan and US.



Over 1000 dedicated professionals.



Close to 500'000 peripherals installed all over the globe

rimon

Spin-off | **ETH** zürich

Our vision is to transform the global workforce, fostering a future where anyone can excel in any technical field



ETH zürich



Rimon's closed loop knowledge process captures knowledge and upskills talent

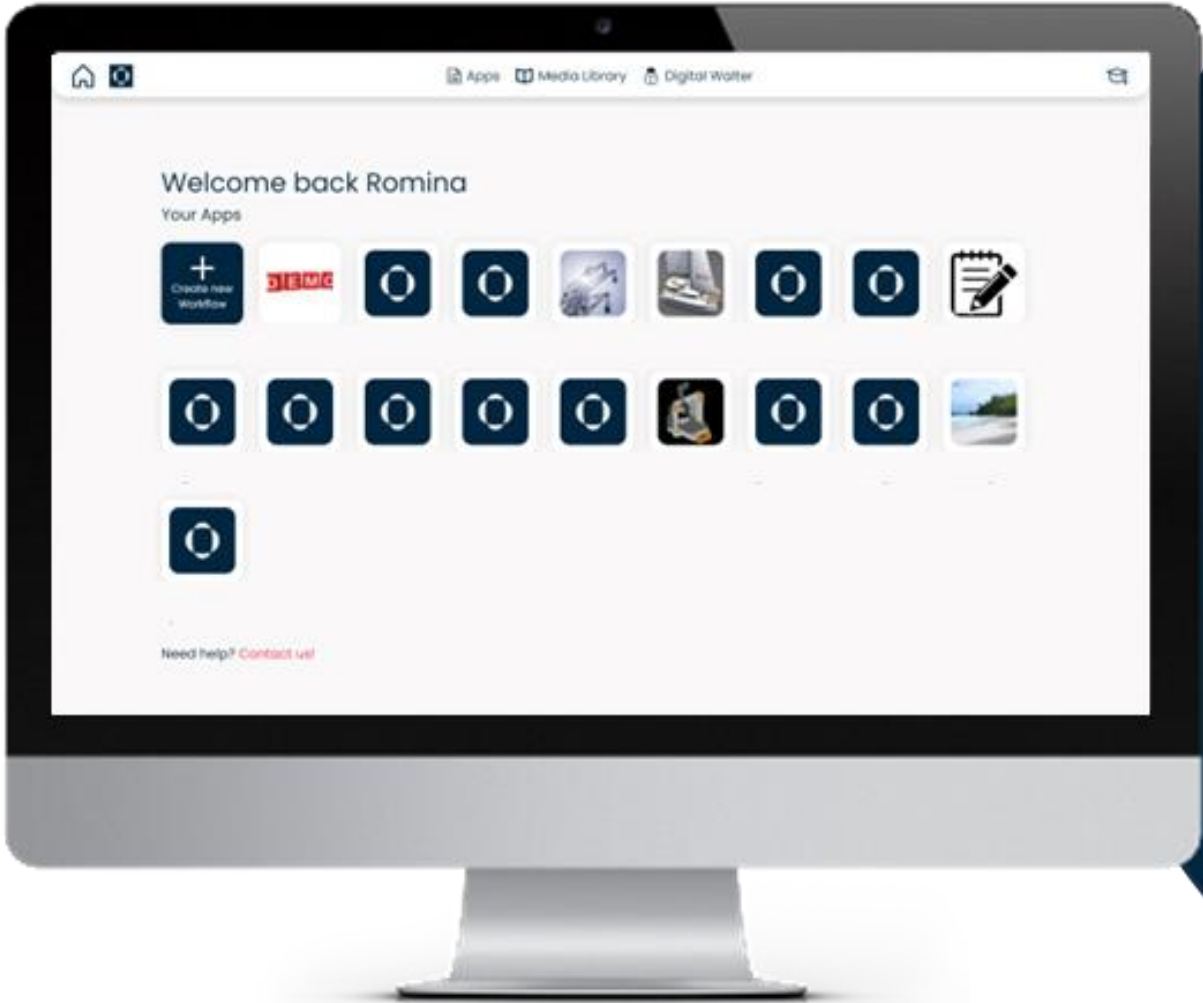

rimon Hub
Smart knowledge management

 <https://hub.rimon.tech>
h

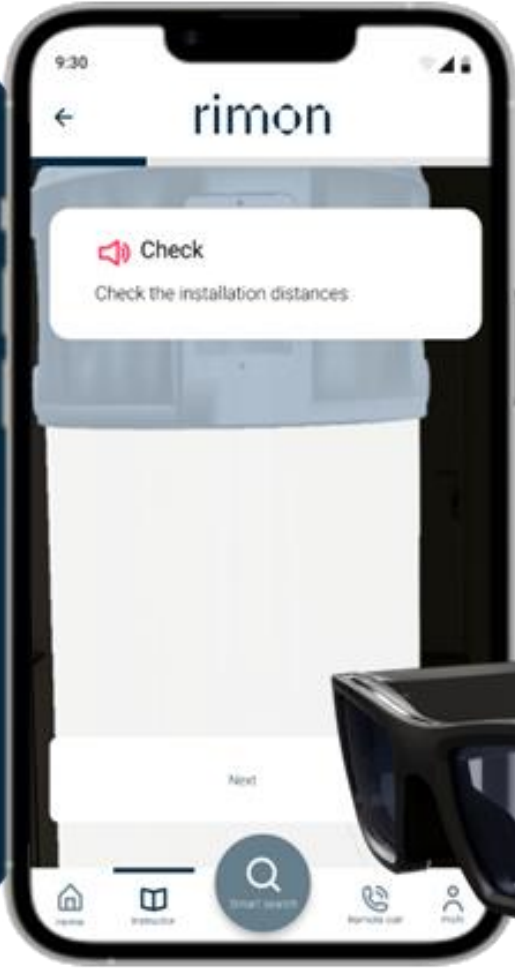
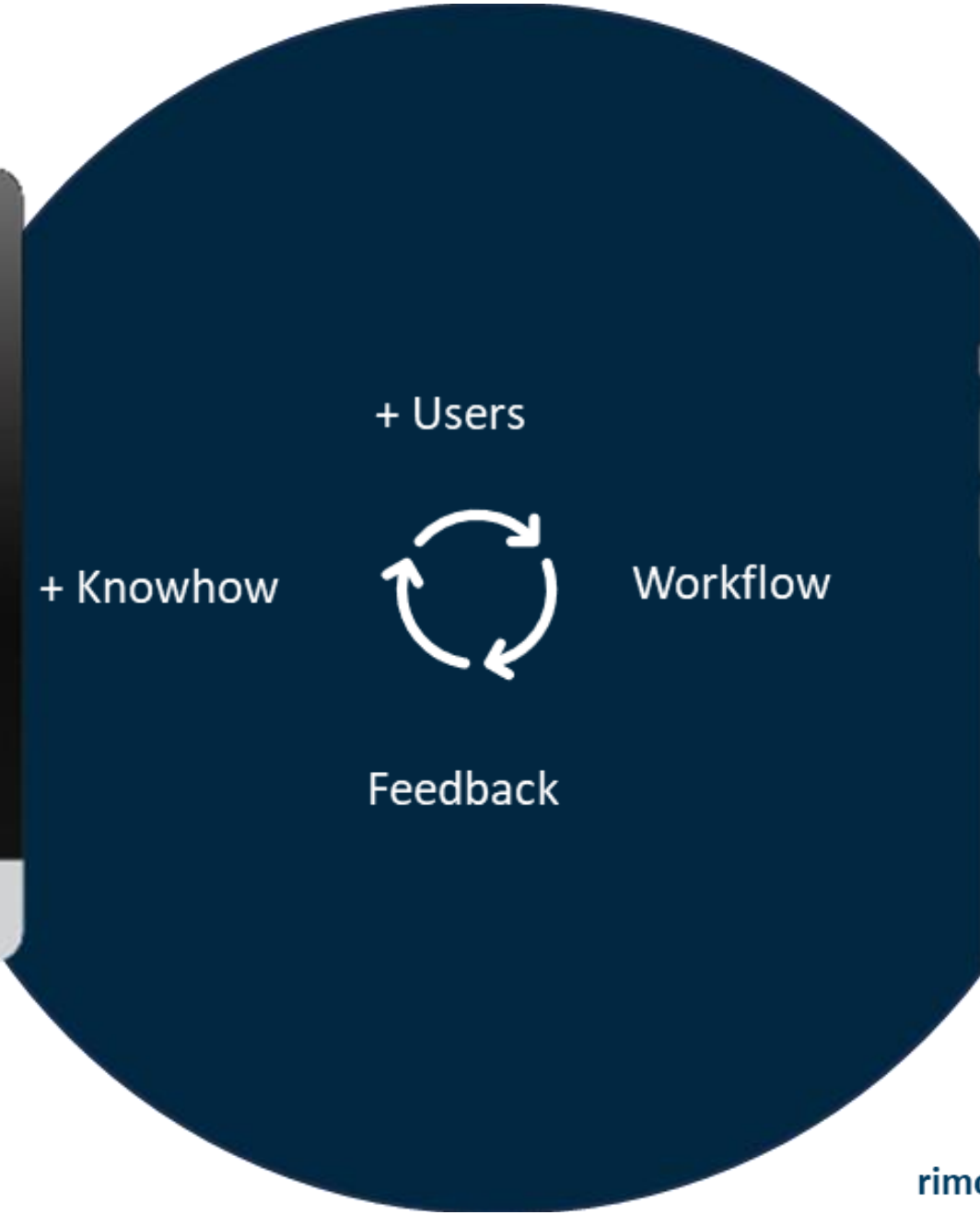

rimon Go
Knowledge capture and retrieval

 GET IT ON Google Play  Download on the App Store  Get it from Microsoft



The system can increase the quality of inspections and simplify processes. Even for new employees who are not familiar with the facilities, the use is a clear advantage that ensures the transfer of knowledge.

Ernst Zogg –
Grid Maintenance Manager,
Swissgrid

The best closed loop system for organizational learning directly from the field with network effect



New digital services and solutions which extend the LNS offering and differentiate us from the competition





Excellence in troubleshooting and maintenance processes is a differentiator





**Adecco Skills
Shortage Index 2022**

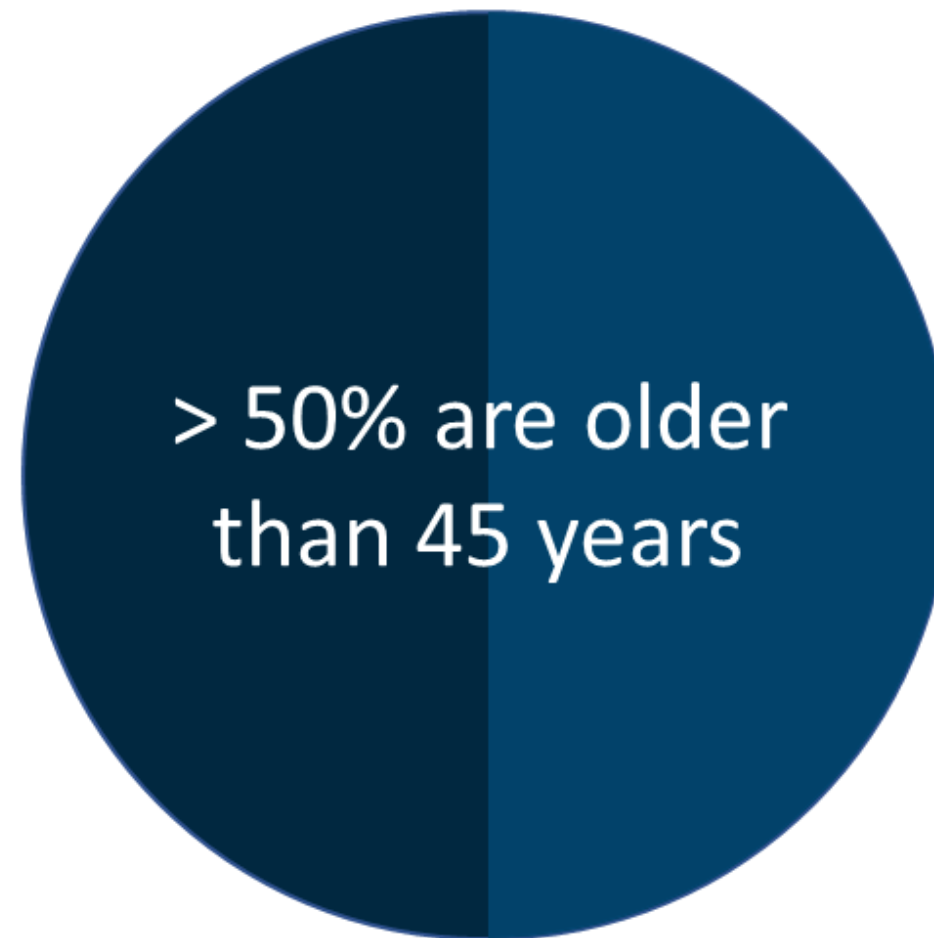

**Number of employees
will decrease**



**Fewer and fewer experts
in the company**



Two-Phase-Approach to build the LNS Chatbot

Phase 1: Test the market

- Build a basic chatbot as an MVP which will be able to answer simple questions and help the customer to open service tickets.

Phase 2: Build sophisticated chatbot

- Build a ChatGPT-like bot leveraging AI and XR with external partners.



“AI enables an automated information retrieval system and with the newest Language Models a new way of interacting with the information in a simple and efficient way. Extended Reality (XR) supports the user guidance directly on the machine, so less specialized users can execute difficult tasks.”



rimon

LNS

THANK YOU FOR YOUR
ATTENTION!