



This presentation was automatically generated in English by  Copilot

Exhibitors' Committee

September 4, 2025



Agenda

of the dinner session



- 1) Partakers
- 0) Hors SIAMS
- 1) SIAMS 2026 – State of play
- 2) List of improvements
- 3) Other ideas
- 4) Strategic reminder
- 5) Diverse

Exhibitor Committee

September 4, 2025

Code of the day

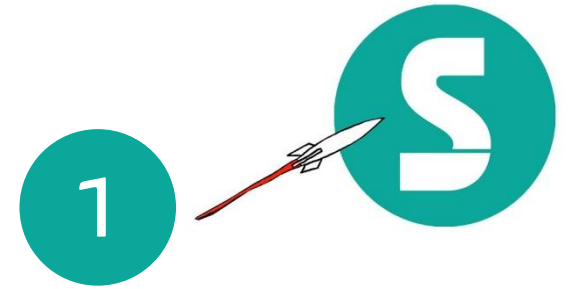

- Grey is light (or thereabouts)
- Green is in progress (or we want to give you more details)
- Screens are links
- The orange pile requires decisions (and/or ideas)
- Don't hesitate to intervene at any time ;o)



Welcome to the new

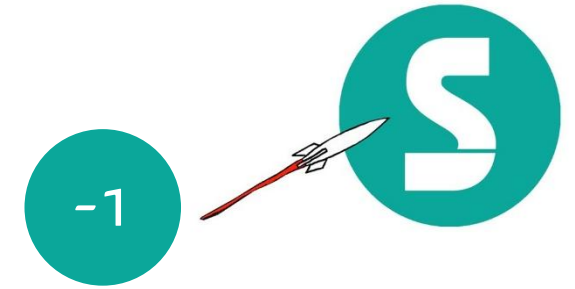

- Round table



Excluding SIAMS

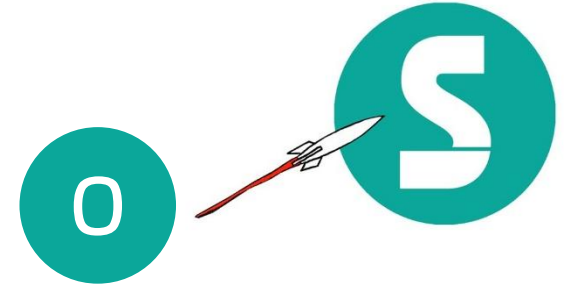

- 3rd Idea Pitch - 27.10.2025
 - News
- 5th SIAMS Club event – 01/02. 2025
 - Grenoble
- 1st Sustainability Forum with i-moutier – 20.3 2025
 - 100+ participants, very positive feedback
- 3rd SIAMS TV Days – ? to ? April 2027
 - 3 exciting days
 - Available online

3rd Pitch idea – SAVE the date

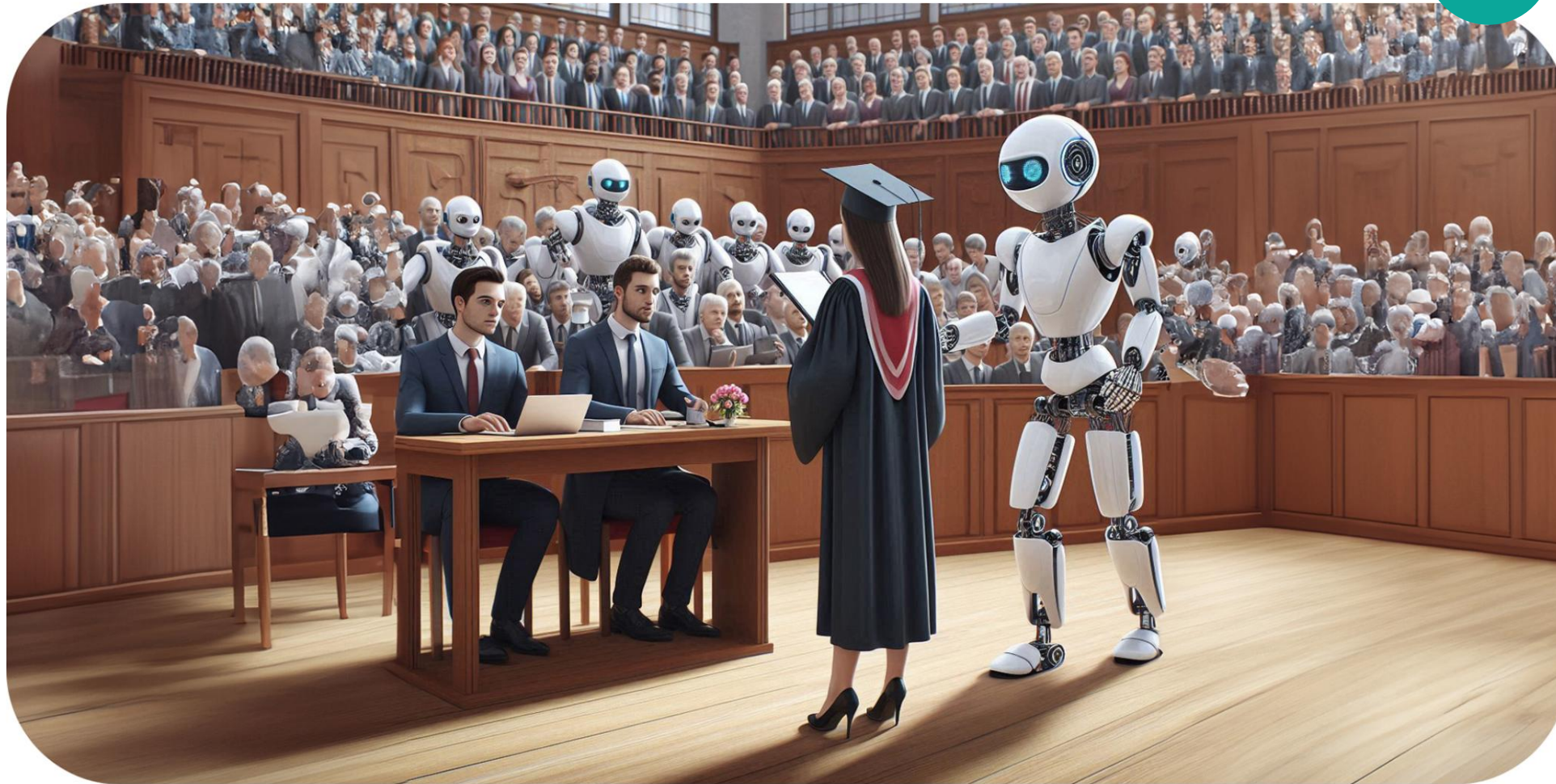

27.10.2025



Report on the second Pitch idé



Club SIAMS



- Basic idea: Grenoble
- Participation in the festival **tech&f**

- Visit to 3 cutting-edge

Under discussion:

- Leader (employees)
- ... on site

... and exchange evening

Event Cancelled



6.-7.02.2025



Club SIAMS



- Basic idea: Grenoble
- Participation in the festival **tech&f**

- Visit to 3 cutting-edge

Under discussion:

- Leadership (employees)
- Location on site

We're so sad

... and exchange evening



- Are we relaunching a great thing for 2026-2027?



6.-7.02.2025

1st Sustainability Forum

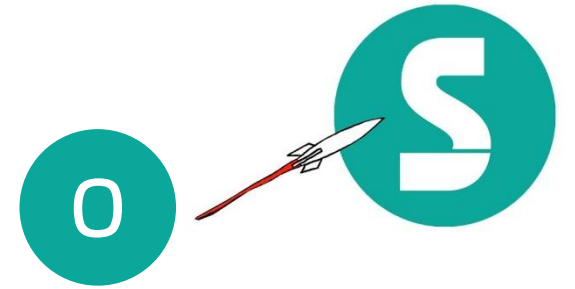

- In collaboration with i-moutier
 - Every ~~2 years in the spring~~, year in the fall at the Forum de l'Arc. Next: August 26, 2026
 - Between 80 and 100 people
- Program
 - 1 day.
 - Experts, group work, feedback
- Topics
 - Sustainability report (non-financial)
 - Legal framework, document templates
 - Sharing experience and best practices
 - Environmental, product, social aspects
 - Governance aspects



- Interesting topics for you? (+ Exp. Sharing)

27.03.2025

2nd SIAMS TV-Days

- ~~5~~ 3 days,
- ~~Art. 10~~ 6 x 30-minute shows
- ~~5~~ 3 x 5-minute shows
- ~~15~~ 9 participating companies
 - Industry Issues and Challenges
 - 35,017 viewers (main shows)
 - 186,165 viewers (short shows)
 - Very positive qualitative feedback
 - Marketing materials for participants
 - Use by SIAMS
 - **More?**

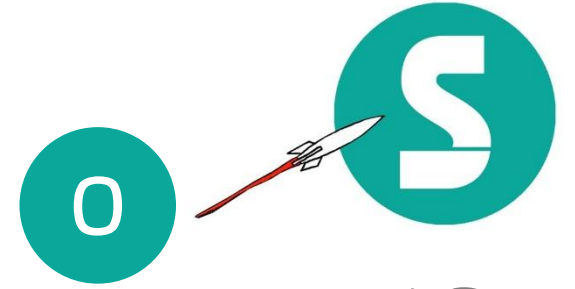

07-11.04.2025

3rd SIAMS TV-Days

- April 21-24, 2027
- 5 days,
- 10 x 30-minute shows
- 5 x 5-minute shows
- 15 participating companies
- Industry Issues and Challenges



- **Register now**
 - Discount for "bulk order and well in advance"??

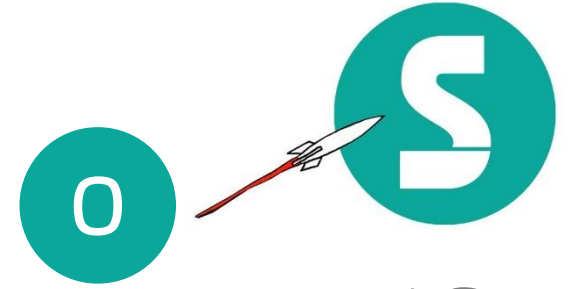

07-11.04.2025

State of play

- New website

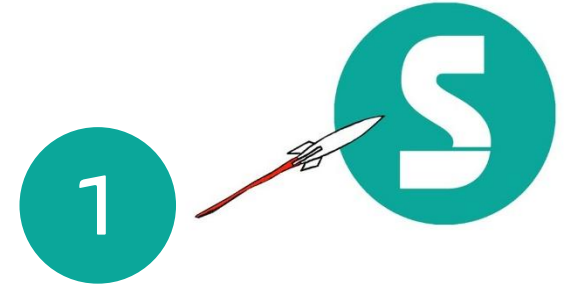

SIAMS

21-24 | 04 | 2026

SIAMIS

- New website

Se connecter

Se souvenir de moi ?

[Mot de passe perdu ?](#)

[Demander votre login](#)

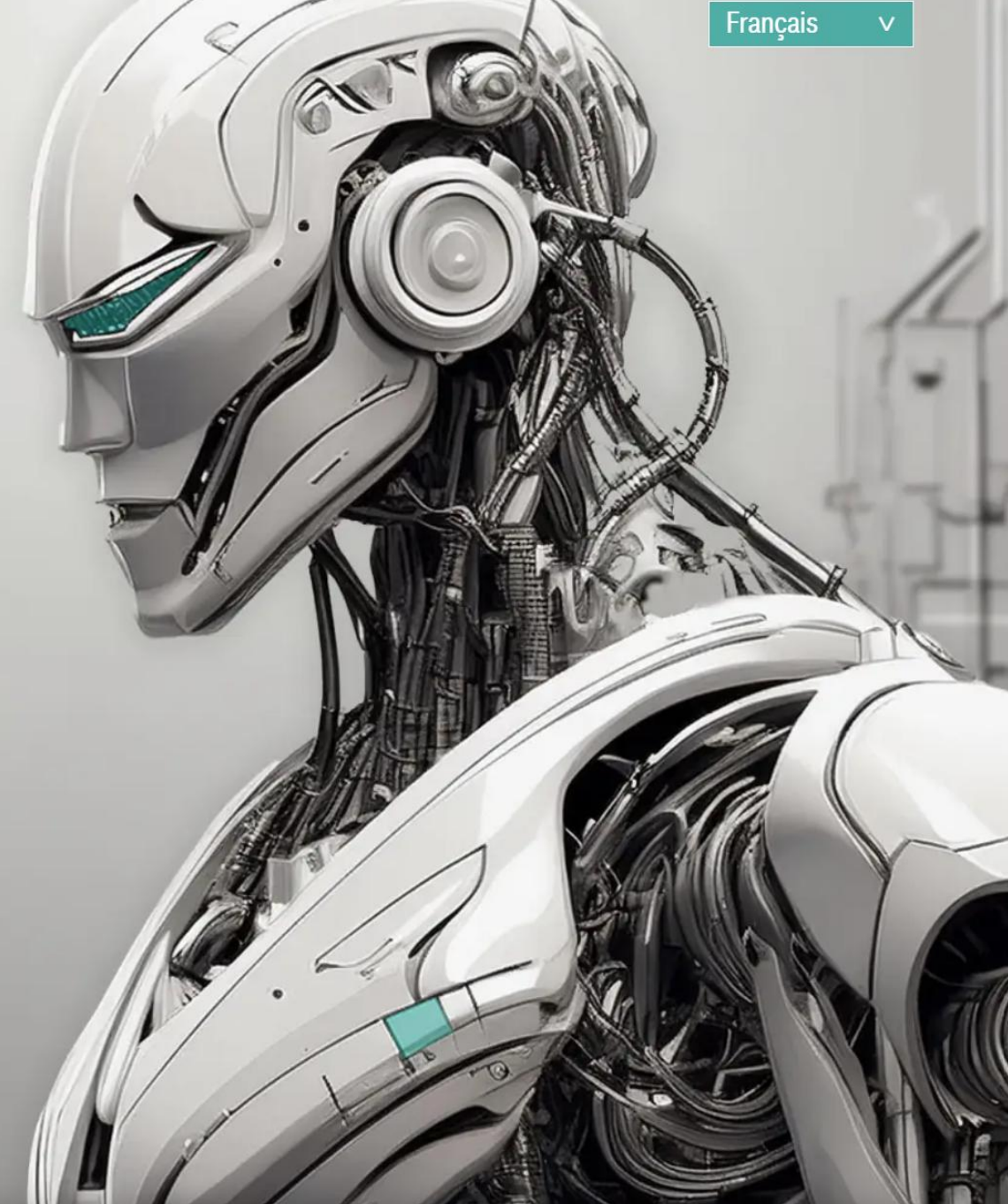

State of play - 21 -24 | 04 | 2026

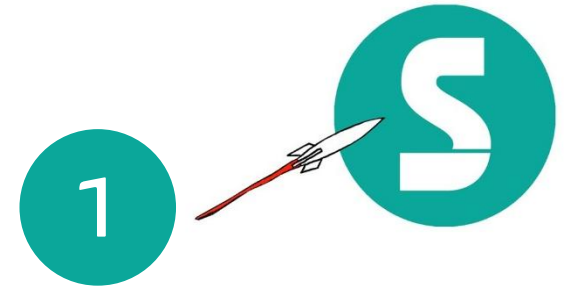

- No price change
- 100% filling! Thank you!!!
 - Some cancellations compensated
- **Parkings -200 vs 2024 (!?)**
- Articulated week like the other years
- **Inauguration**
 - OK EBS
 - **Marco Sieber in progress**
-  2 evenings of conferences
 - **With CEP on Tuesday >Idée? Opening up markets and working "among ourselves"**
 - With the economic promotions on Wednesday
 - State Councillors of the three cantons confirmed
- 1 festive evening
 - Dan Mudd confirmed

State of play - 21 -24 | 04 | 2026

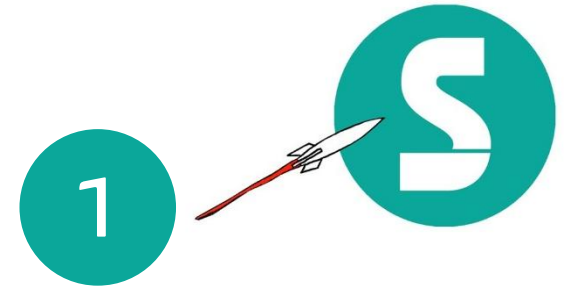

- Breakfasts
 - With CSEM Wednesday – High tech.
 - With i-moutier Thursday – sustainability
 - With Proman (?) Friday – HR and recruitment



- RH breakfast
 - Yes?
 - Theme?
 - Collaborations?
 - Ideas (what do you need?)

State of play - 21 -24 | 04 | 2026

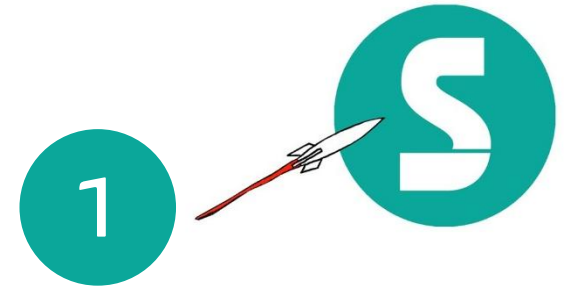

Communication from and for SIAMS

- Advertising in the trade press (F&D)
- **Social media**
 - **Linkedin News: shares**
 - **Your own SIAMS news tags**
- Press releases (next: next week)
- Press event (next: 6 and 7 November)
- Newsletter
 - From the specialized press
 - Partners (CEP, chambers of commerce, etc.)
 - Economic promotion event
- Broadcasts with Canal Alpha and RFJ/RJB/RTN

State of play - 21 -24 | 04 | 2026

Communication from and for SIAMS

- New column on RFJ

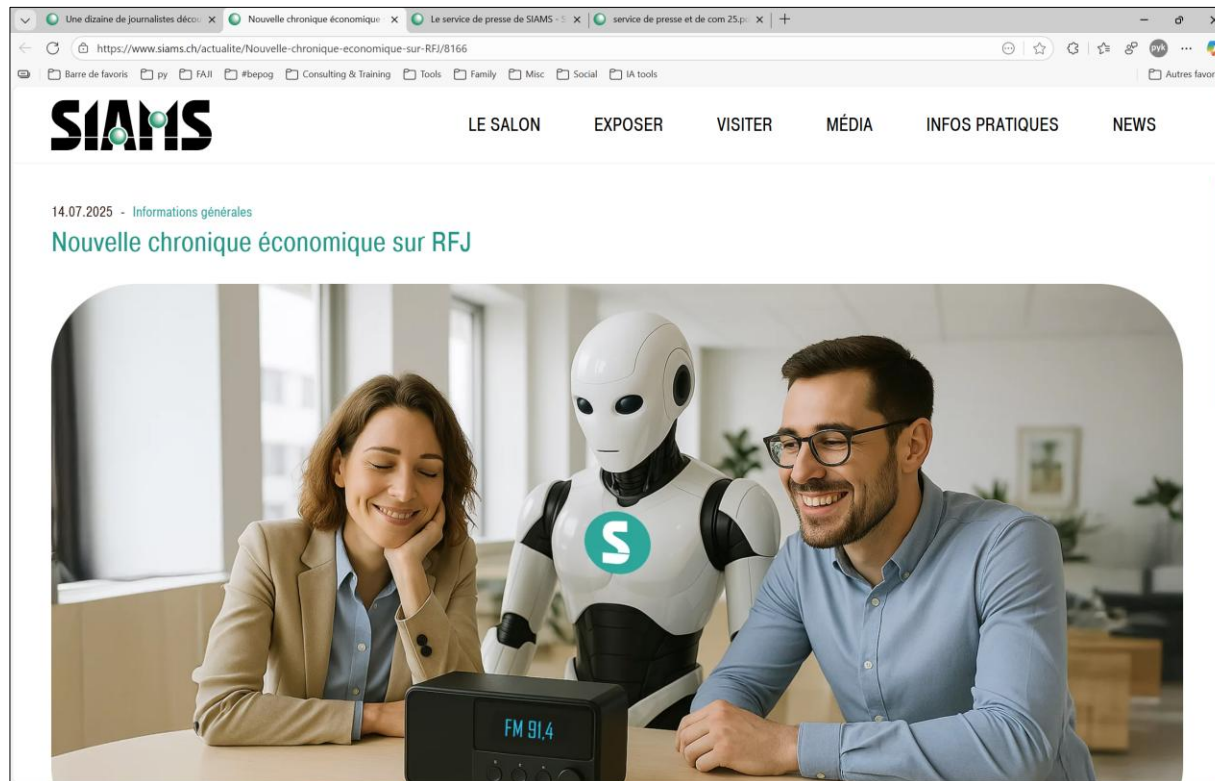
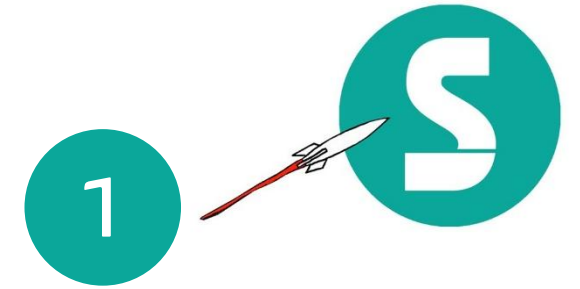

www.siams.ch/jura

State of play - 21 -24 | 04 | 2026

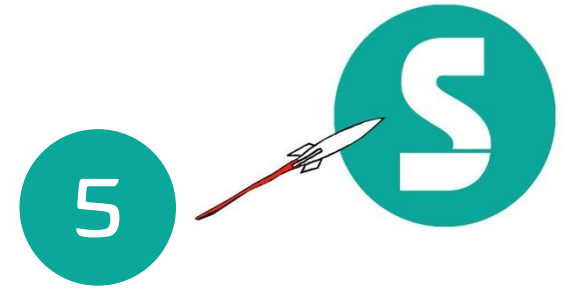

- SIAMS in the Jura?!
- Nothing changes!
- The excellent cooperation with the three economic promotions of the cantons of Bern, Neuchâtel and Jura continues
- Our local contacts remain the same
- **FAJI is also recognised as a public utility in the Jura!**
 - Our philosophy remains the same.
 - A priori we are not going to turn into a "money pump" to the detriment of our exhibitors ;o).

SIAMS Campaign 2025 - 2026

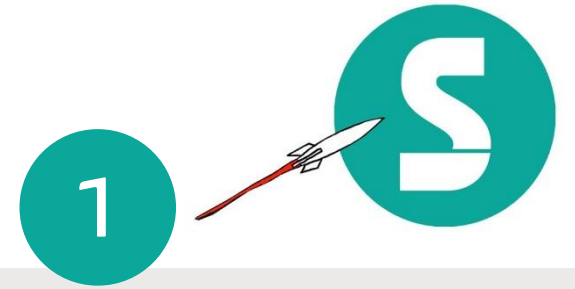

INVEST A DAY
IN MOUTIER SO YOU DON'T MAKE A MISTAKE

SIAMS Campaign 2025 - 2026

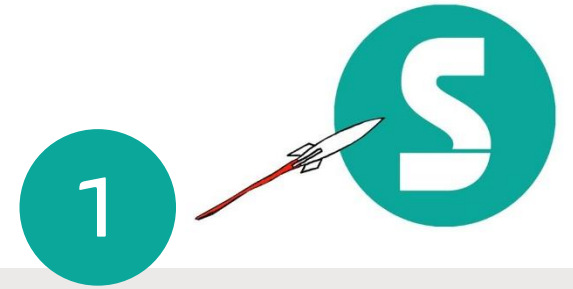

LE CHOIX DE TOUS LES ÉLÉMENTS DE VOTRE
CHAÎNE DE PRODUCTION EST UN ENGAGEMENT SÉRIEUX!
FAITES LE BON CHOIX!

INVESTISSEZ UNE JOURNÉE
À MOUTIER POUR NE PAS VOUS TROMPER

+ toute l'année en ligne sur le portail d'informations microtechniques www.siams.ch

Save the dates!
21-24 | 04 | 2026 MOUTIER,
FORUM DE L'ARC
AU CŒUR DE L'ÉCOSYSTÈME MICROTECHNIQUE DE L'ARC JURASSIEN

SIAMS

LE CHOIX DE TOUS LES ÉLÉMENTS DE VOTRE
CHAÎNE DE PRODUCTION N'EST PAS UNE LOTÉRIE
NE LAISSEZ RIEN AU HASARD!

INVESTISSEZ UNE JOURNÉE
À MOUTIER POUR NE PAS VOUS TROMPER

+ toute l'année en ligne sur le portail d'informations microtechniques www.siams.ch

Save the dates!
21-24 | 04 | 2026 MOUTIER,
FORUM DE L'ARC
AU CŒUR DE L'ÉCOSYSTÈME MICROTECHNIQUE DE L'ARC JURASSIEN

SIAMS

LE CHOIX DE TOUS LES ÉLÉMENTS DE VOTRE
CHAÎNE DE PRODUCTION NÉCESSITE UNE VISION ÉCLAIRÉE
FAITES LE BON CHOIX!

INVESTISSEZ UNE JOURNÉE
À MOUTIER POUR NE PAS VOUS TROMPER

+ toute l'année en ligne sur le portail d'informations microtechniques www.siams.ch

Save the dates!
21-24 | 04 | 2026 MOUTIER,
FORUM DE L'ARC
AU CŒUR DE L'ÉCOSYSTÈME MICROTECHNIQUE DE L'ARC JURASSIEN

SIAMS

Poster

- Standard and custom (more on that later)

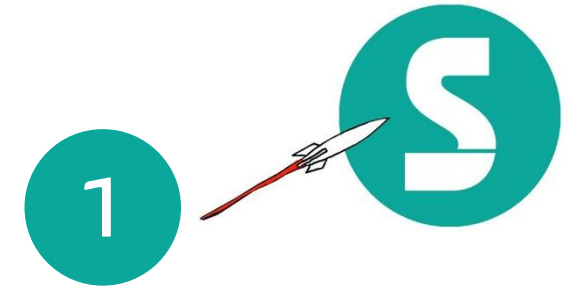

LE CHOIX DE TOUS LES ÉLÉMENTS DE VOTRE CHAÎNE DE PRODUCTION EST UN ENGAGEMENT SÉRIeux!

FAITES LE BON CHOIX!

INVESTISSEZ UNE JOURNÉE À MOUTIER POUR NE PAS VOUS TROMPER

+ toute l'année en ligne sur le portail d'informations microtechniques www.siams.ch

DIE AUSWAHL ALLER ELEMENTE IHRER PRODUKTIONSKETTE IST EINE AUSSERST WICHTIGE ANGELEGENHEIT!

TREFFEN SIE DIE RICHTIGE WAHL!

INVESTIEREN SIE EINEN TAG IN MOUTIER, UM SICHER ZU GEHEN!

+ das ganze Jahr über online auf dem Infoportal der Mikrotechnik www.siams.ch

AU CŒUR DE L'ARC JURASSIEN DES MICROTECHNIQUES 
SIAMS : le salon de l'ensemble de la chaîne de production des microtechniques
9.00 - 17h.30 (17h.00 vendredi)
Billets d'entrée gratuits à télécharger (à partir février 2026) : www.siams.ch/tickets

IM HERZEN DES JURABOGENS DER MIKROTECHNIK 
SIAMS : die Messe für die gesamte Produktionskette der Mikrotechnik
9.00 - 17.30 (Freitag 17.00)
Gratis-Eintrittskarten zum Download bis Februar 2026 : www.siams.ch/tickets

MOUTIER, FORUM DE L'ARC

SIAMS

Save the dates!
21-24 | 04 | 2026

LE CHOIX DE TOUS LES ÉLÉMENTS DE VOTRE CHAÎNE DE PRODUCTION N'EST PAS UNE LOTERIE

NE LAISSEZ RIEN AU HASARD!

INVESTISSEZ UNE JOURNÉE À MOUTIER POUR NE PAS VOUS TROMPER

+ toute l'année en ligne sur le portail d'informations microtechniques www.siams.ch

Billets d'entrée gratuits à télécharger (à partir février 2026) : www.siams.ch/tickets

vasconi SA  SWISS TOOLS SOLUTIONS

Halle 1.2 | F13

Vasconi vous attend avec toutes ses nouveautés !!!

En plus des outils coupants spécifiques, venez découvrir nos micro-outils PCD hélicoïdaux ainsi que notre pôle Sous-Traitance Mécanique de précision !!!

Save the dates!
21-24 | 04 | 2026

MOUTIER, FORUM DE L'ARC
9h00 - 17h30 (17h00 vendredi)

SIAMS

AU CŒUR DE L'ÉCOSYSTÈME MICROTECHNIQUE DE L'ARC JURASSIEN 

State of play - 21 -24 | 04 | 2026

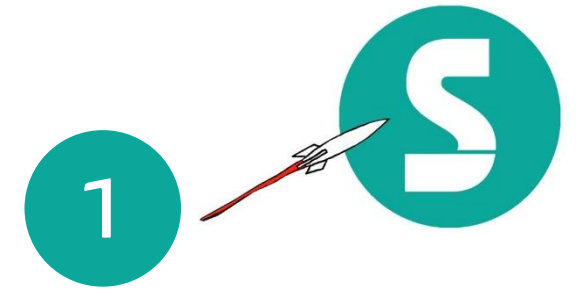

Foreign visitors?

- Should we invest to attract more foreigners? Leads welcome ;o).

RÉPARTITION GÉOGRAPHIQUE

Très satisfaits de la provenance des visiteurs

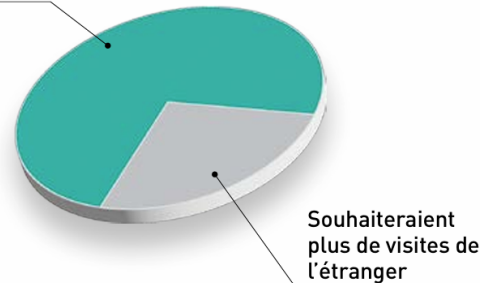

Avec 12% de visiteurs étrangers de 30 pays, le SIAMS reste prioritairement un salon suisse. À la question de la nécessité d'augmenter le visitorat international, les exposants répondent majoritairement non (à 75,65%).

VISITORAT

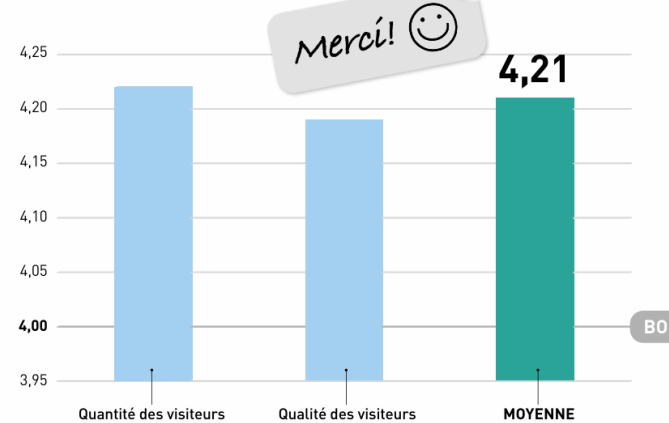

Avec 14'208 visiteurs, l'édition 2024 de SIAMS a été très fréquentée. Les exposants estiment le nombre de visiteurs sur leur stand très bon à excellent. Idem en ce qui concerne la qualité de ces derniers. La performance est valorisée par une note de 4,21 sur 5.



State of play - 21 -24 | 04 | 2026

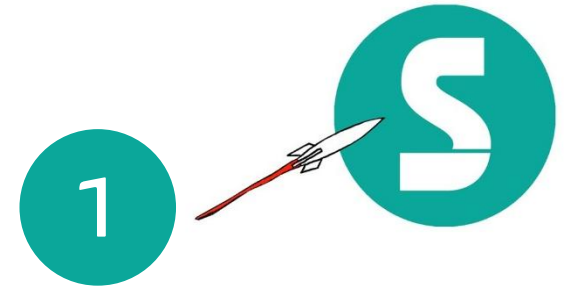

What we do...



- By economic promotions (interested companies)
- Foreign partner newsletters (quite few)
- Advertising and public relations

ROTA THW3
autocentrante automatico con cambio rapido morsetti

Grazie al sistema a brucia stagna brevettato, gli intervalli di manutenzione sono più lunghi e l'utilizzo è più sicuro e silenzioso.

schunk.com →

Hand in hand for tomorrow

www.mtm-tornitura.it

Report
SIAMS MOUTIER 2026

Instancabili e sempre alla ricerca dell'eccellenza

LA mesi dell'evento e con le conferme definitive per la registrazione degli espositori... **NUOVA PIATTAFORMA PER GLI ESPOSITORI**... **INNOVAZIONE IN MOVIMENTO**... **SIAMS MOUTIER 2026**... **LA PRIMA RIVISTA ITALIANA DEDICATA ALLA FILIERA DELLA TORNITURA**

Per approfondimenti: www.mtm-tornitura.it

Giacomo Barca - 1er
Chez D.F. Edizioni srl - MTM Magazines - Tornitura Show Exhibition Vicenza - F...
17 h - Modifié

Online il numero n°3/2025 di MTM Tornitura con un'importante novità: da oggi la rivista sarà sempre più house organ di **Tornitura Show** diventando la rivista di tutta la filiera della tornitura comprendendo, oltre ai macchinari, gli accessori, gli utensili, anche le aziende che effettuano lavorazioni di SUBFORNITURA.

In questo numero troverete, quindi, le aziende end user quali:

- Officina Meccanica Menotti s.r.l.
- LA.P.M.(www.lapm.it)
- Capitani Minuterie Metalliche
- O.MET officina meccanica(www.o-met.it)
- Trattamenti Termici Todesco
- Facchi Franco srl(www.facchi.com)
- Daminelli S.R.L.
- Tormatic(www.tormatic.it)
- X-Turn(www.x-turn.it)
- OMCCR (www.omcrr.it)
- Fapasalvi (www.fapasalvi.it)
- TA srl (www.ta-srl.it)
- LGA (lgaossidazioneodica.it).

Gli articoli:

- "Innovazione in movimento" in collaborazione con HAINBUCH Italia
- "Tornitura Show 2025 ha colpito nel segno a Vicenza"
- "Tornos Swiss DT7 e DT10", in collaborazione con Tornos Group
- "Sistemi di misura Mitutoyo", in collaborazione con MITUTOYO ITALIANA SRL
- "EMAG MSC 5 DUO", in collaborazione con EMAG Group
- "Ridurre le vibrazioni su fantina fissa", in collaborazione con IEMCA
- "Doppio tagliente, doppia durata", in collaborazione con Walter Tools
- "Cerchi dipendenti? Crea i presupposti", in collaborazione con Chemma
- "Una seconda vita per gli utensili", in collaborazione con Sandvik Coromant
- "Superfici regolari e senza imperfezioni", in collaborazione con Renishaw
- "SIAMS Moutier 2026, in collaborazione con Pierre-Yves Kohler



Improvements

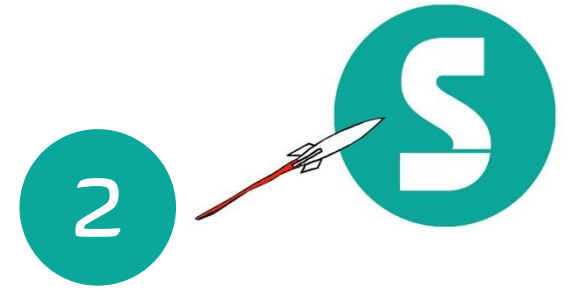

-  **Special bracelets or badges?**
 - Decision to abolish the "2024" bracelets
 - Replaced by "different" badges
 - Replaced by another strap (removable)
-  **More toilets**
- **Elimination of paper flyers**
 - How do you invite your customers?
 - Producing a PDF doc anyway?
- **Car parks and stickers**
 - Valid for the week
 - Different colors per day
- **Raclette no longer allowed**
- **Crockery**
 - Improvement of the washing offer
 - Made-to-order suppliers

List of improvements and questions

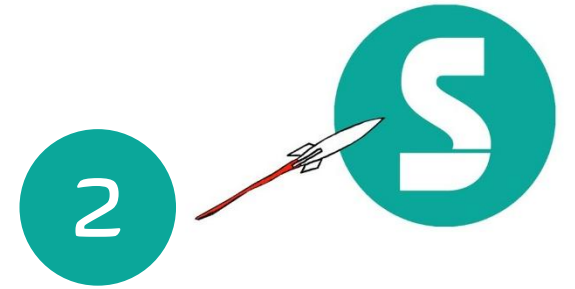

- More about the services offered

- We are frustrated



- HR Day

- Friday
 - Signage "open post?"
 - Breakfast?
 - Other actions?

- Visitor Community (SIAMS QR 26)

- Related to company visits (do not multiply messages)

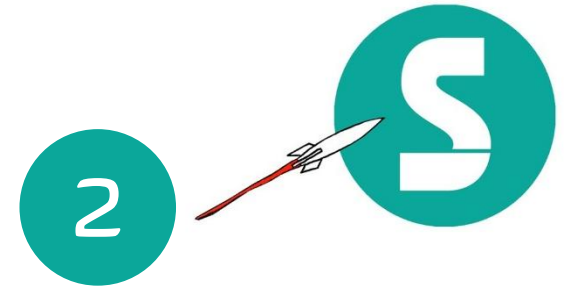

List of improvements

- Better manage the storage space of empty packaging
 - Best flow for disassembly
 - **Express booking system. 1 Pallet X 4 Frames!**
- New schedule for assembly
 - Open Sunday, April 19 (no service)
 - Monday 20 April 5:00 p.m., release of the aisles and installation of the carpet
 - [New timetable summary document](#)
 - Catering from 15 to 17 April and from 20 April



2024 Changes Active Again

- Podiums: constraints related to empty packaging
- WIFI – Simplified access
- Open earlier for exhibitors

Building

- Arrival of visitors
 - Put an airlock

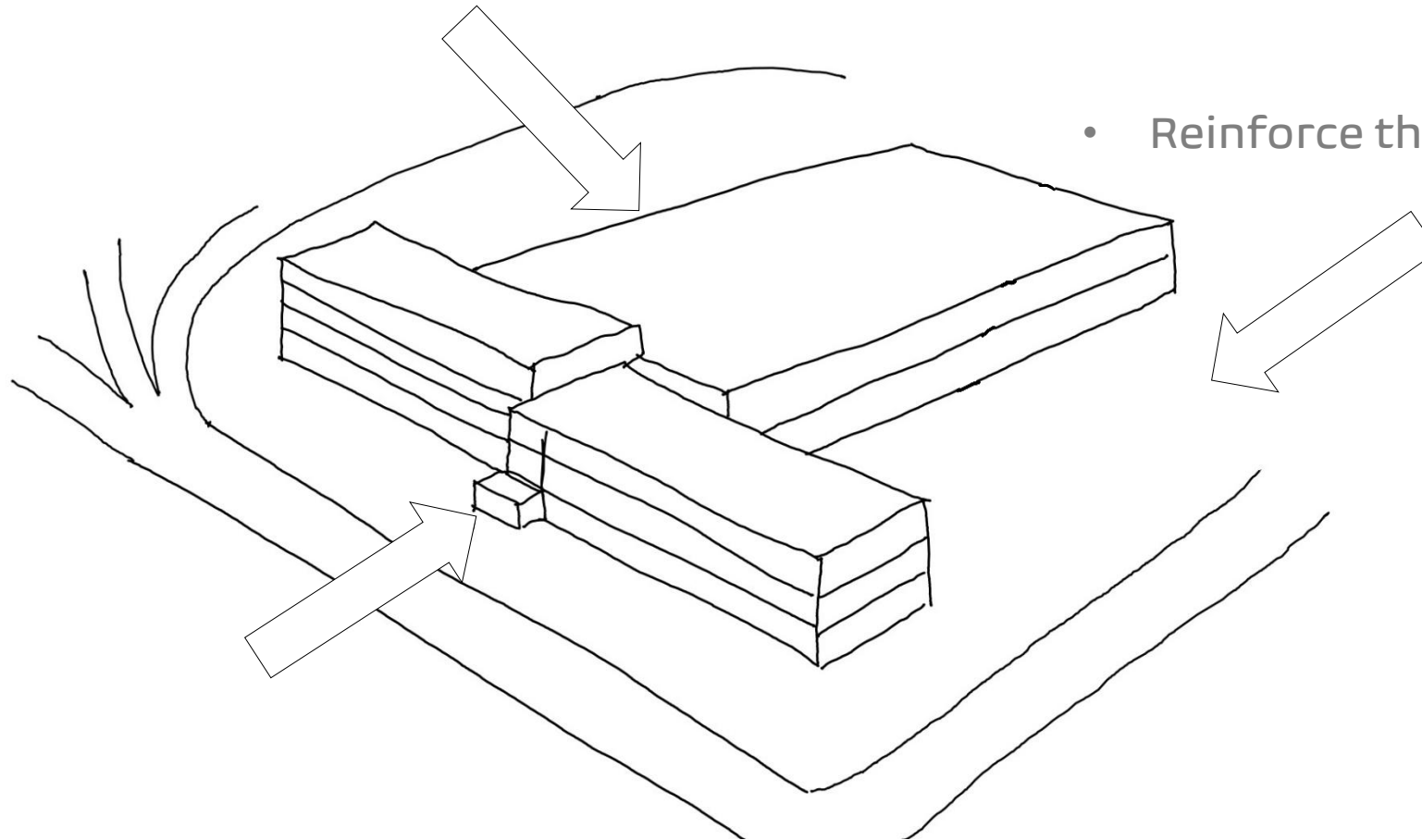
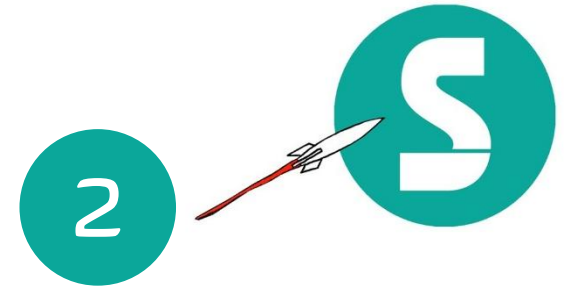

- Reinforce the entrance through th

List of improvements

- Building transformation

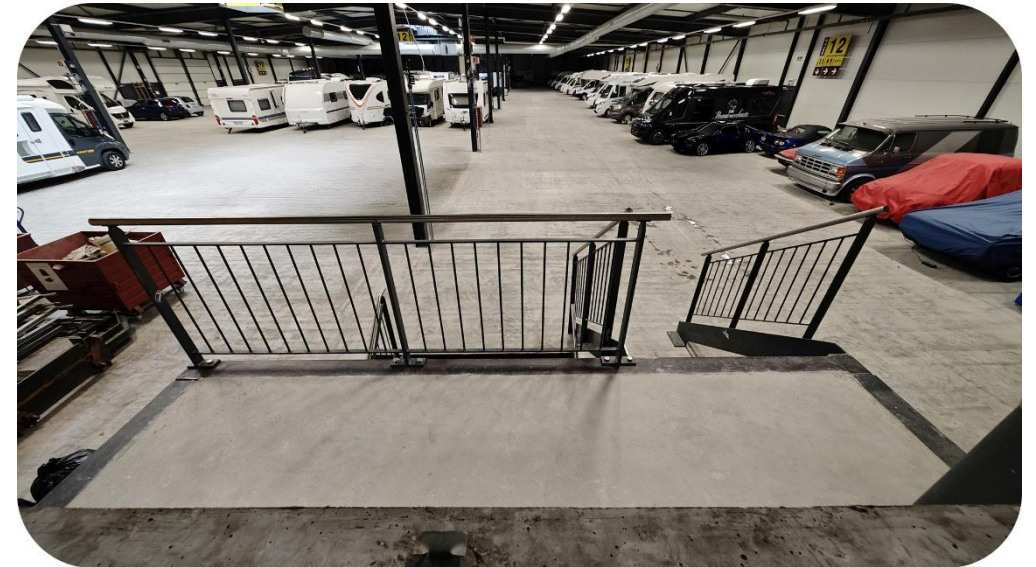
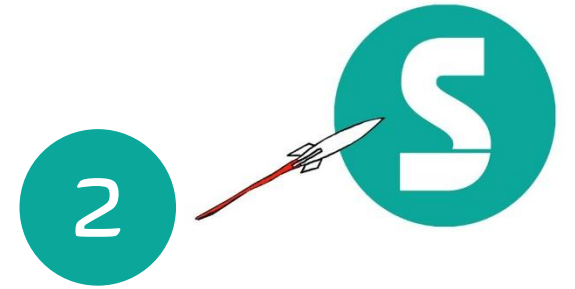

Visitor reception

- Carpooling platform
- Car parks in Moutier
 - Paid abandoned
 - The Laives in progress
 - Gorges de Court in progress
- In Delémont? (unmotivated people)
- In Granges?

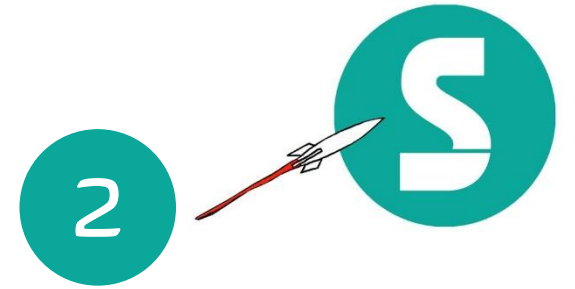

Registration for post-SIAMS visit

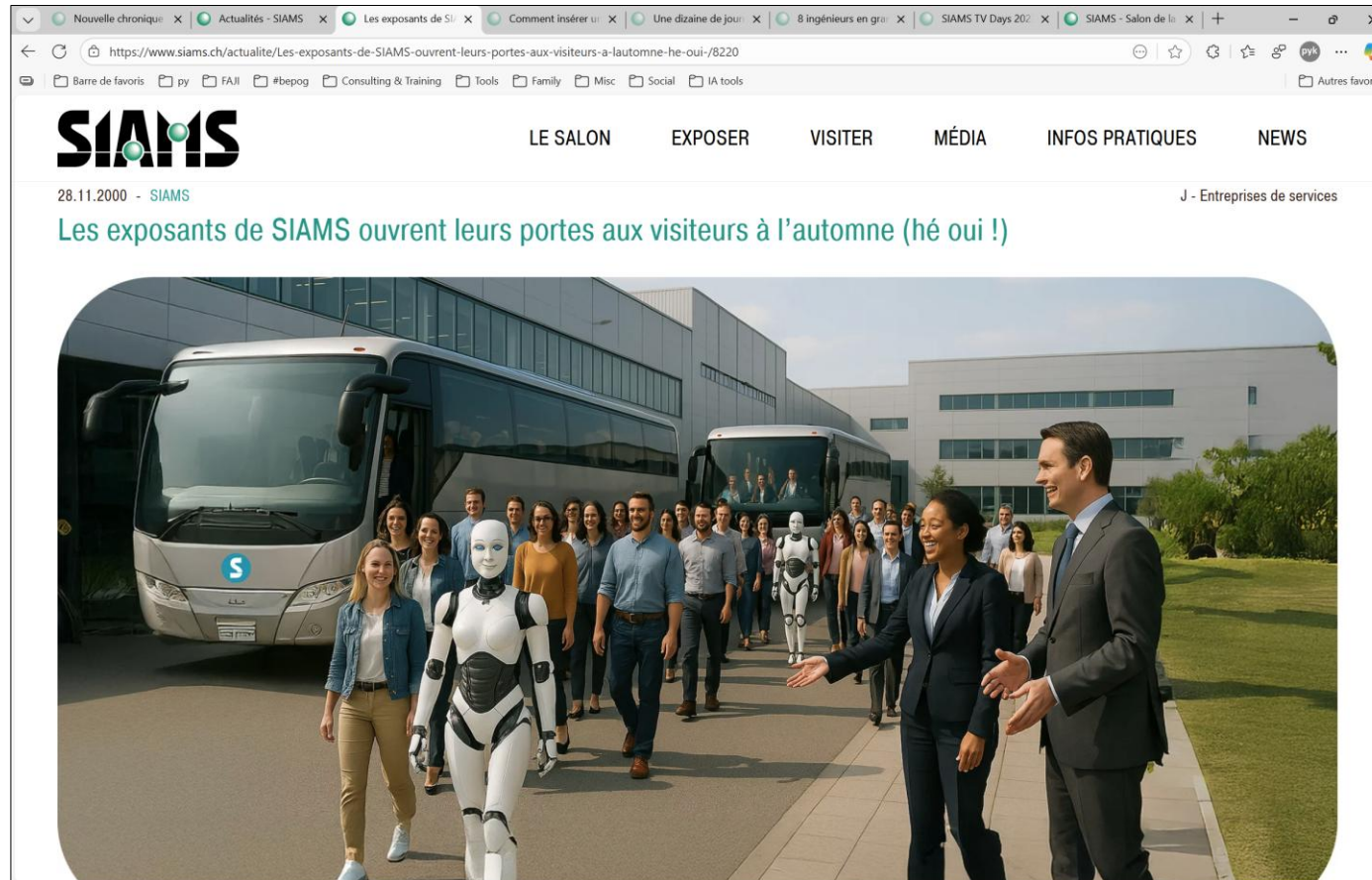
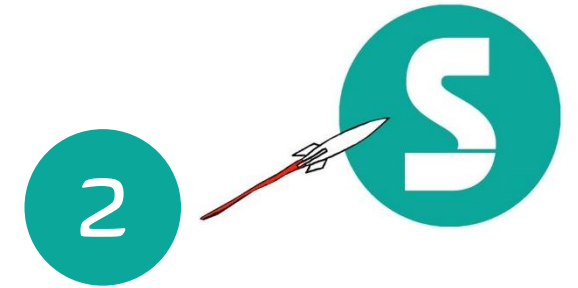

- Discussion of the idea
- Period? (we fix)
- Financing (e.g., bus)? ((Free for visitors?))
- Who would be up for it?

List of improvements

- The tools available

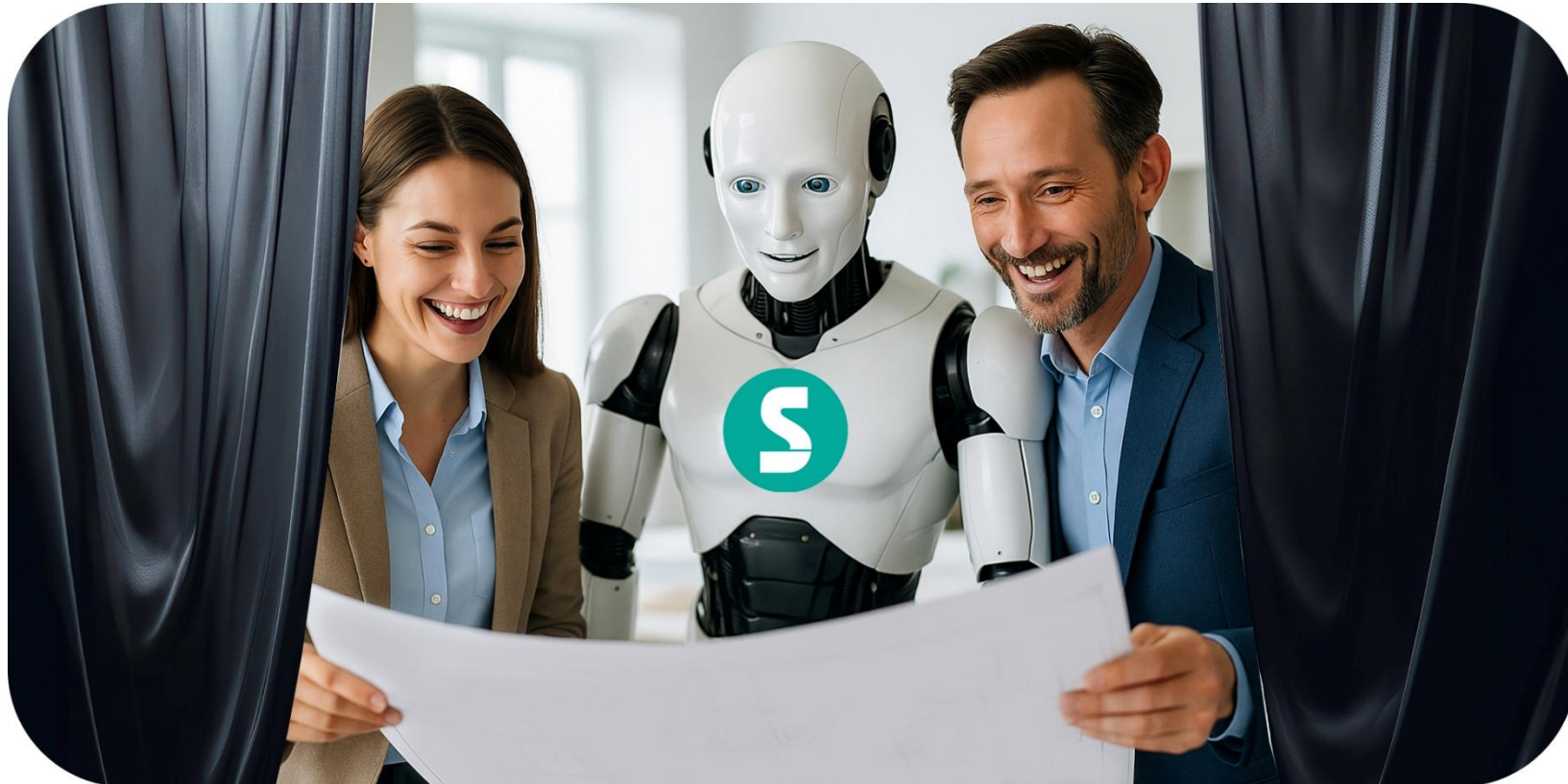
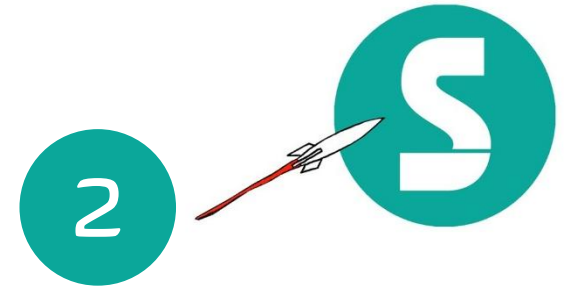

List of improvements

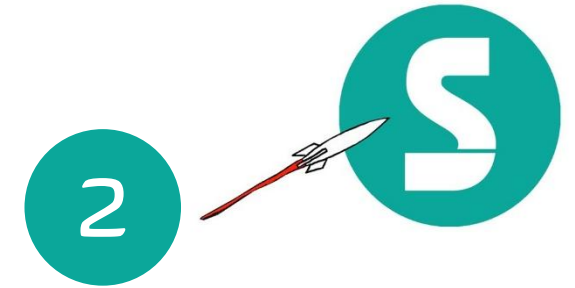

- The tools available
 - Detail improvements
 - Reorganization of the news
 - We need to communicate more (how?)

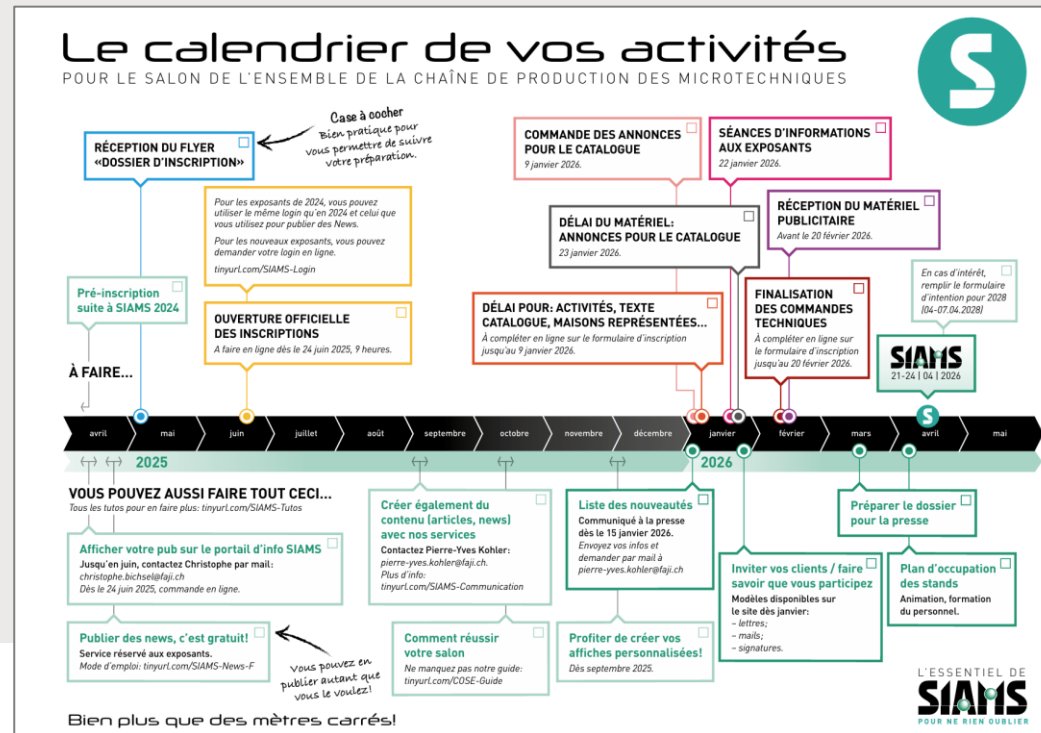

Exemples



vasconi SA
SWISS TOOLS SOLUTIONS

Halle 1.2 | F13

Vasconi vous attend avec toutes ses nouveautés !!!

En plus des outils coupants spécifiques, venez découvrir nos micro-outils PCD hélicoïdaux ainsi que notre pôle Sous-Traitance Mécanique de précision !!!

Save the dates!
21-24 | 04 | 2026

MOUTIER,
FORUM DE L'ARC
9h00 - 17h30 (17h00 vendredi)

SIAMS

AU CŒUR DE L'ÉCOSYSTÈME MICROTECHNIQUE DE L'ARC JURASSIEN



Logo

Title

Key message

Hall and stand

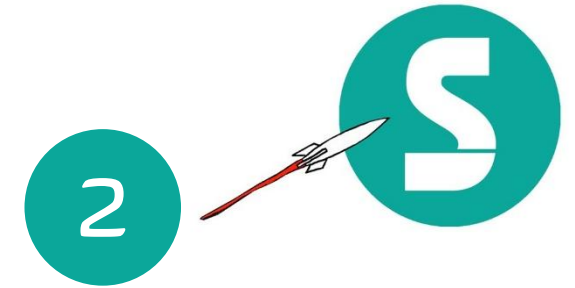

Exemples

2



Logo

Title

Key message

Link on details page

Visuels de la campagne *Investissez une journée à Moutier pour ne pas vous tromper!* (>>Pour tout savoir, c'est ici).

Press Office

2



26.05.2025 - Informations générales

Une dizaine de journalistes découvrent la barrière anti particule la plus stylée!

Conférence de presse Roxer du 22 mai 2025: première étape de la mise en valeur des nouveaux flux laminaires qui ambitionnent de changer le monde horloger mo

La création de contenu

- Simple
- Rapide
- Efficace
- Sans souci

Qui & Quoi
Exclusif pour les clients de SIAMS
Une prestation complète de création de contenu et de diffusion de messages (presse, sites internet, réseaux, etc.)

Comment
C'est tout simple!
Interview, réalisation, soumission, validation, envoi pour diffusion. Nos garanties de qualité et de suivi assurent la satisfaction de nos clients et la rapidité d'actualisation de votre contenu.

Combien
140 CHF/heure + frais
Budget moyen compris entre 1500 et 3000 CHF.

Les services SIAMS



Any other need/idea?

Communication

- News SIAMS
- LinkedIn/Facebook/X

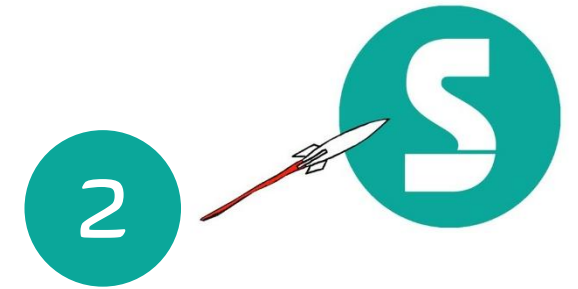

Tout pour communiquer plus efficacement

Participer à SIAMS est une superbe opportunité de se présenter sous son meilleur jour à Moutier (tous les deux ans), mais également de communiquer largement entre deux éditions.



Programme complet de mise en valeur

Chères exposantes, Chers exposants, Nous vous offrons la possibilité de mettre vos nouveautés (et/ou caractéristiques particulières) en valeur pour la prochaine édition de SIAMS par le biais de la presse spécialisée.



Page d'accueil (et d'invitation) personnalisée disponible pour l'édition 2026

Cette super possibilité est également disponible avec la nouvelle plateforme. Invitez vos clients avec style ;o).



En direct du laboratoire SIAMS...

Quoi de neuf dans les laboratoires d'innovation de SIAMS?



Le MSM dresse un état des lieux de SIAMS 2026 . Merci 😊

L'édition annuelle de MSM/SMM vient de sortir et elle est copieuse. Vous y découvrirez 134 pages de contenu passionnant.

New website and social

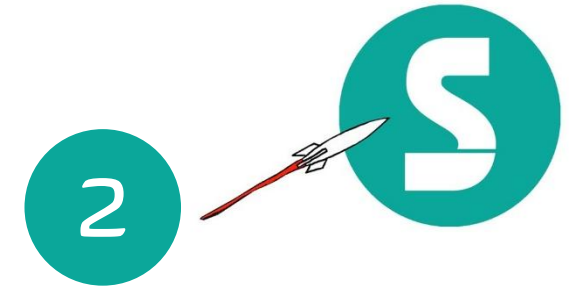

- Custom exhibitor indicators
 - Google analytics, data protection > to be analysed

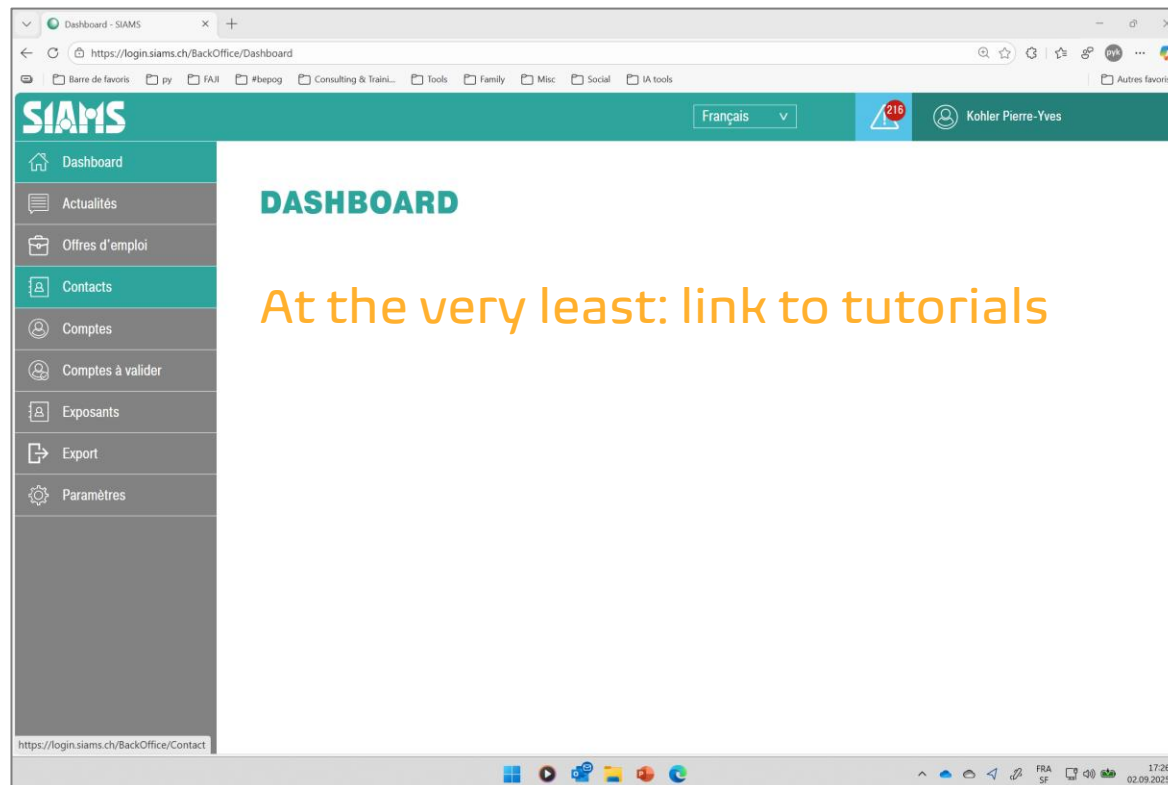

New website and social

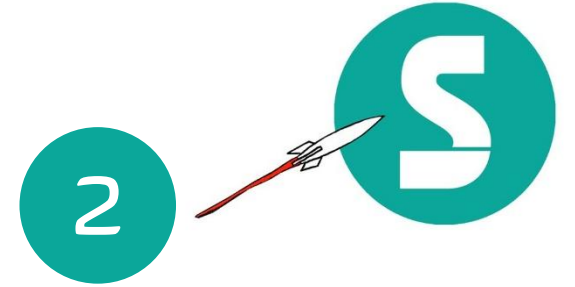

- Custom exhibitor indicators
 - Google analytics, data protection > to be analysed
- **Possibility of an "app"**
 - Mixed web version, reduced investment, "only" advantage: notifications. Abandoned
- Second part 2024-2025 (registration)
 - Registration openings
 - Still a lot of work to be done
- LinkedIn Group
 - 2,904 subscribers, a slow increase (1,769 at the last committee)
 - Do more?



Organizers Club

Reference content (exhibitor committee)

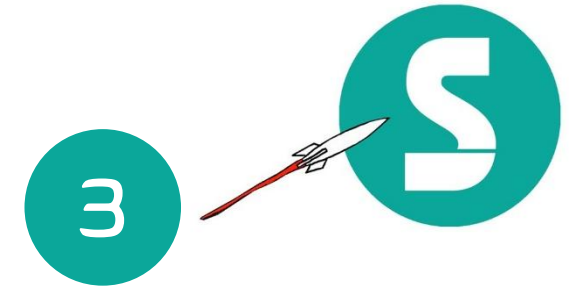

Les services

Quelques notions de communication et de mise en valeur !

Aujourd'hui, disposer de supers produits et services est indispensable... mais si vos clients potentiels n'en connaissent pas l'existence (et encore moins les avantages), il est très difficile de les vendre.

Chères exposantes, chers exposants,

Avec le SIAMS, vous disposez d'un superbe outil pour présenter vos solutions là où ça compte. [Là où les clients peuvent dire "oui" à vos offres](#). Mais le SIAMS vous offre "plus" pour être présents toute l'année dans le monde microtechnique. Vous pouvez communiquer par le portail d'informations microtechniques et publier autant de nouvelles que vous le souhaitez ([Mode d'emploi: publication de news \(2016\)](#))... mais ça n'est pas tout !

Créer du contenu n'est pas toujours facile (et vous n'avez pas nécessairement le temps). Bonne nouvelle :o). Nous vous proposons un service (payant) de réalisation de contenu pour la création d'articles présentant vos produits et solutions (et/ou votre entreprise) destinés à la presse spécialisée.

Pour tout savoir, c'est ici : [le service de presse de SIAMS](#)

Et si on commençait simplement ?
Vous souhaitez en faire un peu plus sans nécessairement utiliser nos services ? Dans les pages qui suivent, nous vous donnons quelques informations de base pouvant vous aider !

Comment

1. Réaliser un communiqué de presse.
2. Réaliser un dossier de presse.
3. Réaliser une conférence de presse.
4. Réfléchir à son argumentation.
5. Développer un concept publicitaire.

Le document « Comment réussir votre salon » que nous avons créé avec des organisateurs d'expositions européens est toujours disponible en ligne ici : [voir guide "Comment réussir votre salon" \(PDF\)](#).

FAI SA | Industrielle 98 | 2740 Moutier Page 1 sur 6

Comment réussir votre salon

Club des Organisateurs de Salons Industriels Européens



Any other need/idea?
How can you be better informed?



INNOTEQ micronora



Strategic Reminder - Vision

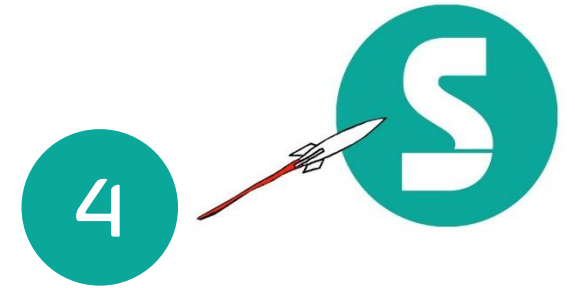

Mission

Enterprise

Neuromarketing

Segments

Positioning

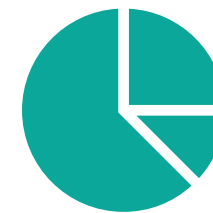
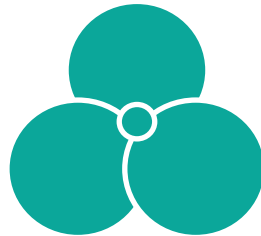

No m2
Opportunities to
meet.

Three axes:
DNA.
Return.
Number 1.

Communicating
and participating
in a trade fair:
complicated and
boring.

2 audiences:
The exhibitors.
Visitors.

The gateway to
the entire
microtechnology
production chain
. at the heart of
the Jura Arc
ecosystem.

> Helping
customers.

> Helping
customers and
making money
profitable.

> Helping
customers,
simplifying
everything... All
year round.

> Helping
customers,
simplifying
everything... all
year round.

Strategic Reminder – Products and Services

4



The living room
The news portal



Overall very good.
Sold out for 2026.
Continuous improvement.
Further simplifying.
Strengthening the community.



Works well. to animate the community.
Evolves every day.
+200 contributors.
14,000 views per month.

The Club



Networking and contact tool.
Animates the community.
Give value to being a part of it.

Services Markom



Enhancement tool.
One more service for exhibitors.
...

SIAMS +



Virtual in 2020.
SIAMS+ in 2021.
TV-DAYS in 2023 and 2025.
Positive experiences.
Market presence.

Strategic Reminder – Products and Challenges

4



The living room
The news portal



To ensure that the Salon remains a must. Improve everything that can be improved.

A microtechnology exhibition?
Le SIAMS.

The Club



Strengthen visibility and services. A simple tool.

A microtechnology information service?
Le SIAMS.

Services Markom



Events for Ensure visibility and enhance value.

Be part of the SIAMS community?
A real added value.



Strengthen information on this subject.

Be part of the SIAMS community?
A real added value.

SIAMS +



To make the SIAMS TV-Days sustainable.

Strengthen the sense of belonging, be present.

Strategic Reminder – Products and Challenges

4



Exhibitors

Visitors



To be present all year round and to support the members of the exhibitor community at SIAMS in all their communication and market presence problems

Simplify everything

What can be done more and better?



Creating the SIAMS visitor community to bring more value to exhibitors
Registration for the visitors' committee at SIAMS 2024
Track changes in customer behaviors and other exposures
General trends and how to respond to them (e.g. ecology and natural resources)

What can be done more and better?

Upcoming ents



3rd Pitches
October 27, 2025
Forum de l'Arc
In collaboration with

SWISS
ENGINEERING
TRANSJURA

haute école
neuchâtel berne jura



ingénierie
www.he-arc.ch



Meeting of the
exhibitors
January 22, 2026
Location to be
defined

In collaboration with



19th SIAMS
April 21-24, 2026
Forum de l'Arc
In collaboration with



2nd Sustainability
Forum
August 6, 2026
Forum de l'Arc
In collaboration with



i-moutier

Upcoming ents



1st day of the relocated SIAMS. To be defined Oct. 2026.

At the exhibitors. In collaboration with



4th Pitches ?? October 2026 Forum de l'Arc

In collaboration with

SWISS ENGINEERING TRANSJURA

haute école neuchâtel berne jura  ingénierie www.he-arc.ch

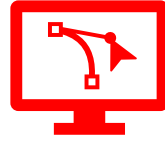

3rd SIAMS TV-Days April 20-23, 2027 On TV and online In collaboration with

canal alpha 



3rd Sustainability Forum ?? Aug. 2027 Forum de l'Arc In collaboration with

 i-moutier



5th Trip of the SIAMS Club To be defined

Upcoming ents



20th SIAMS
04-07.04 2028
Forum de l'Arc
In collaboration
with



The best exhibitors in the universe



SIAMS

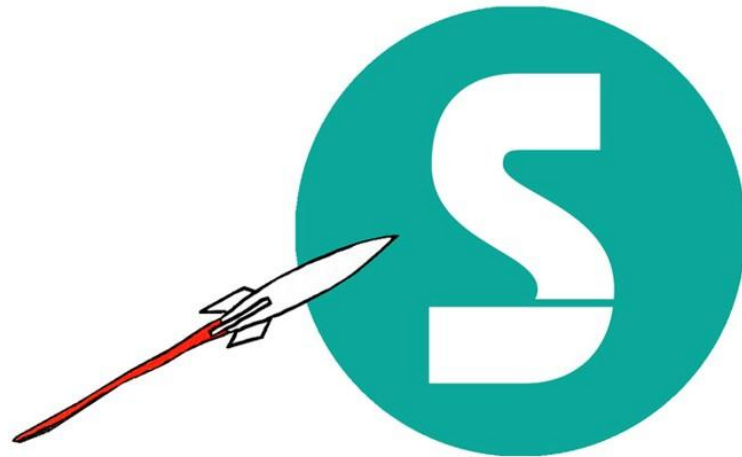

Different since 1989



SIAMS



Thank you
to the best
exhibitor
committee
in the
universe

Much more than m2:
opportunities to meet